

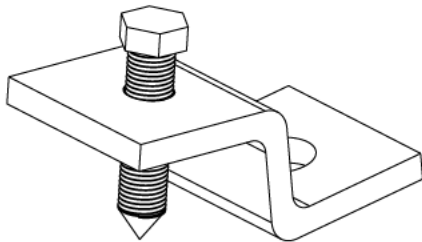

MP41 - CHANNEL BRACKET

Description	MP41 - Z Clamp c/w Cone Point
Finish	Hot Dipped Galvanised
Material	Steel
Packaging	Packed in qty 50
Additional Notes	Supplied with M10 x 40mm 8.8HT BZP Cone Point Bolt Compliant to LU Standard 1-085 (for use on surface & sub-surface locations)

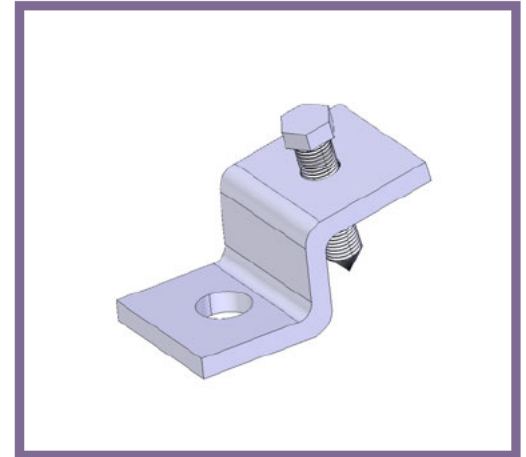

Isometric view

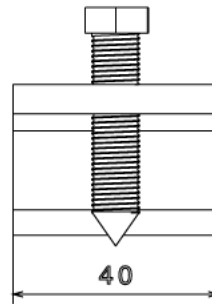

Front view

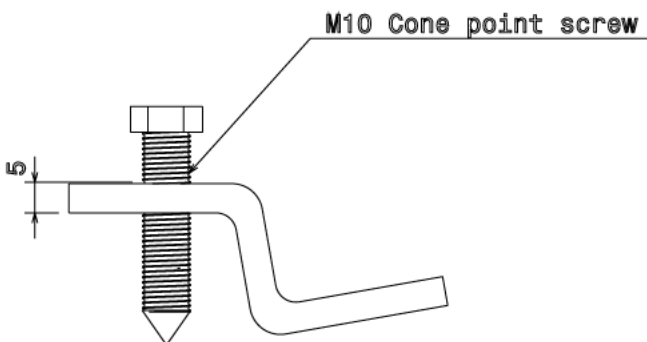

Side view

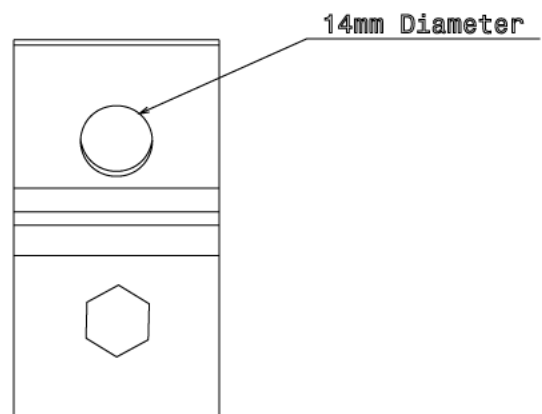

Top view

All measurements in mm unless otherwise stated